

# WMF COFFEEMACHINES

## Operator's Manual



## WMF BISTRO Model Series 8000 / 8100 / 8200

Edition 11 - Printed in 06.06

Item-No.

33 0914 0000



Congratulations on the purchase of your  
WMF COFFEE MACHINE.

Its advanced technology, long service life,  
economy and above all the quality of its  
coffee will delight you.

Please read these operating instructions.  
You will get more pleasure from your  
WMF COFFEE MACHINE and will know  
all there is to know!

**In your own interests, please follow all  
safety and cautionary instructions and pay  
attention to the warning labels placed on  
the machine. This will help to avoid  
accidents and technical malfunctions.**

**Never entrust the machine to anyone who  
is not familiar with the operating  
instructions.**

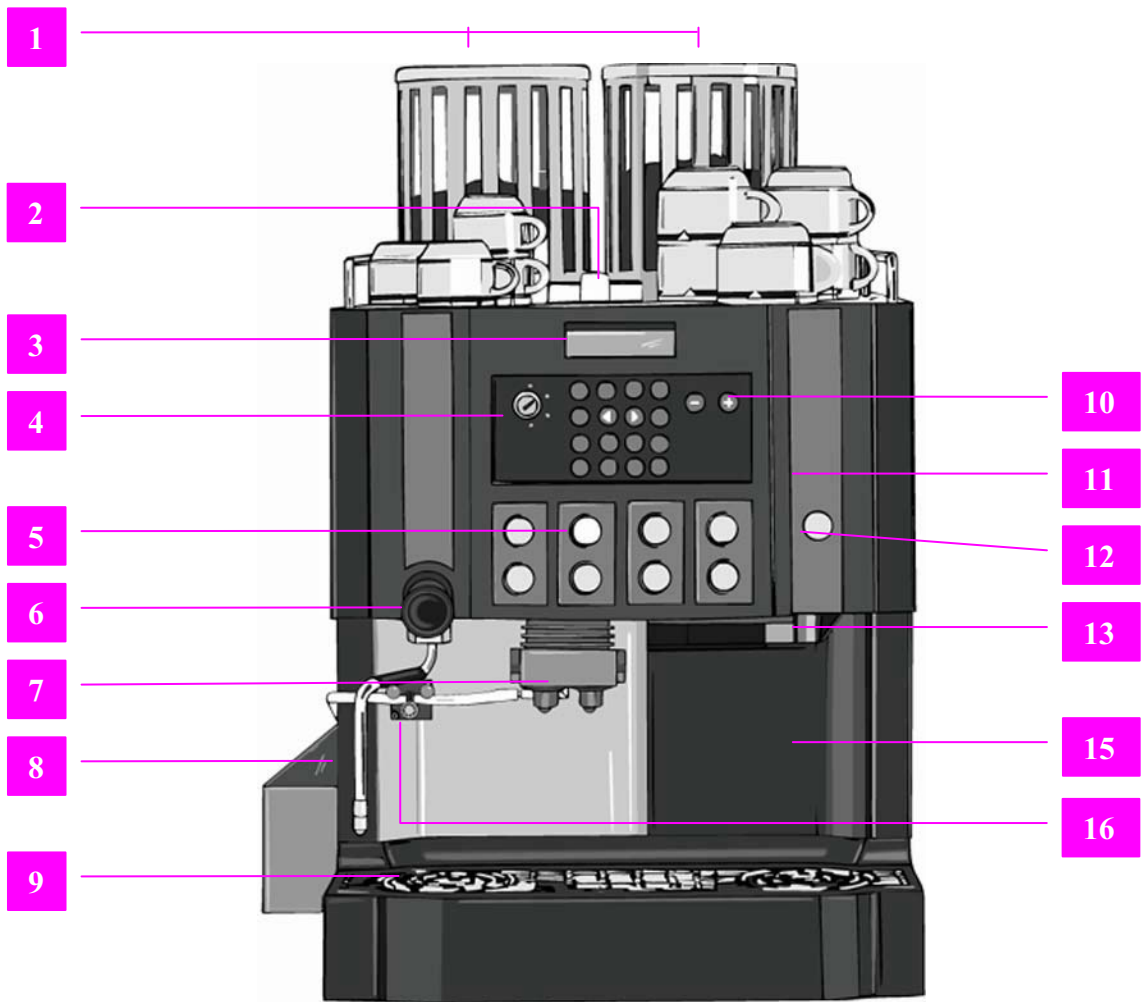
Keep these operating instructions near the  
machine. This will allow your operating  
personnel easy access to information at any  
time, and will enable them to take the  
appropriate action should there be any  
technical malfunctions.

# TABLE OF CONTENTS

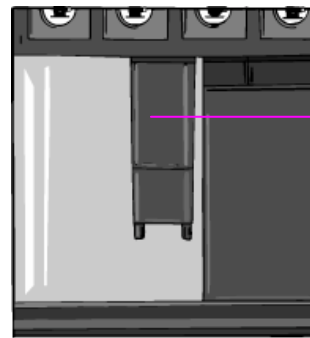
<b>1</b>	<b>Machine features and components</b>	<b>43</b>
<b>2</b>	<b>Warnings</b>	<b>44</b>
<b>3</b>	<b>Safety instructions</b>	<b>45</b>
<b>4</b>	<b>Machine specifications</b>	<b>47</b>
<b>5</b>	<b>Conditions for Installation and Operation</b>	<b>48</b>
<b>6</b>	<b>Operation</b>	<b>49</b>
6.1	Starting the machine	49
6.2	Making coffee	49
6.2.1	Espresso/Café Crème/filtered coffee*	50
6.2.2	Cappuccino	51
6.2.3	Manual input	51
6.2.4	Quantity selection	52
6.3	Coffee beans containers	53
6.4	Hot water dispensing	53
6.5	Steam dispensing (not valid for USA)	54
6.6	Coffee grouts container	55
6.7	Display of quantities dispensed	56
6.8	Personnel accounting system	57
	Sales systems	57
6.10	Switching the machine off	58
<b>7</b>	<b>Settings</b>	<b>59</b>
7.1	Setting froth quality	59
7.2	Quantity selection	60
<b>8</b>	<b>Care of the machine</b>	<b>61</b>
8.1	Daily cleaning	61
8.1.1	Cleaning the machine	62
8.1.2	Cleaning the combination spout	63
8.2	General cleaning	66
<b>9</b>	<b>Error messages and displays</b>	<b>67</b>
9.1	Error messages	67
9.2	Error messages for the operator	67
9.3	Information for the operator	68
<b>10</b>	<b>WMF Customer service</b>	<b>68</b>
<b>11</b>	<b>Liability</b>	<b>69</b>
<b>12</b>	<b>HACCP Cleaning Concept</b>	<b>71</b>

\* ECF model version only





O Off  
 I On  
 R Cleaning  
 A Accounting/programming



# 1 Machine features and components

- 1 Coffee beans containers
- 2 Manual input/cleaning duct
- 3 Display
- 4 Lock switch
- 5 Coffee key
- 6 Rotary handle for steam output
- 7 Combination Spout
- 8 Steam dispensing nozzle
- 9 Drip tray, removable
- 10 Programming keys
- 11 Waiter's lock
- 12 Hot water key
- 13 Hot water outlet
- 14 Swivelling coffee dispenser head
- 15 Coffee grouts container
- 16 Clamping valve

*The following numbers only appear on illustrations in the text:*

- 17 Coin slot
- 18 Coin return chute
- 19 Coin return button
- 20 Control indicator "ON"
- 21 On / Off switch (inside coin box)
- 22 Lockable coin box

## 2 Warnings

Complete machine safety is an integral WMF product characteristic to which we pay particular attention.

In spite of all our safety precautions, however, every machine is potentially hazardous if not operated properly.

This is why – for your own safety – we have summarised the warnings below and highlighted them with a background.

Please observe the “**Safety instructions**” on page 45.

**For your own safety, please observe the following instructions at all times :**



- Connection of the machine and starting up for the first time must only be carried out by WMF customer service technicians
- All maintenance and repair work **must only be carried out by WMF customer service technicians or authorised persons.**  
**Only original parts should be used.**
- **In no circumstances should any alteration be made to the built-in safety devices.**
- **Caution!**  
There is a danger of scalding in the vicinity of the swivelling coffee dispenser head **14**, in the vicinity of the hot water outlet **13** and in the vicinity of the combination spout **7**. Use care when dispensing hot liquids and steam using the swivelling coffee dispenser head **14**, the hot water outlet **13** or the combination spout **7**. The liquid and steam are extremely hot and may scald.
- **Caution! Risk of crushing!**  
Never reach into the coffee hopper **1** when the machine is switched on.
- **Caution! Health hazard!**  
When handling the cleaner, always **follow the safety instructions on the pack**. The cleaner is caustic and can hurt. Because cleaning fluid flows out of the swivelling coffee dispenser head **14** or the combination spout **7** during cleaning, place a collection tank (capacity at least 1.4 litres) below the machine to collect the cleaning fluid safely (for machines without drain connections only).

### 3 Safety instructions

#### General notes

1. At the end of the working day always ensure that the shut-off device on the water pipe supplying the machine is closed and the main power switch to which the machine is connected is switched off and/or the plug is removed from the socket.
2. The component-tested safety devices fitted prevent inadmissible pressure and temperature rise in the boiler. If the safety valve is activated, the machine should be switched off immediately at the customer's main switch. Switch off the machine if a boiler malfunction occurs. Contact the WMF customer service department and do not switch the machine on again until the fault has been remedied.
3. This machine is not for use out of doors. In case of freezing the machine should be drained beforehand to prevent frost damage.
4. Never spray the machine with a hose. Steam cleaners, steam-jet cleaners and similar equipment must not be used to clean the machine. Clean the surface by wiping with a damp cloth, or use products from our WMF care range.
5. The unit must stand safe at a ground level, on a horizontal and stable base.

#### Machine shutdown – holidays

1. If the machine is to be shut down for an extended period, a general clean should be carried out beforehand and the grouts container must be emptied. If there is any risk of freezing, the machine should be drained beforehand to prevent frost damage. In such cases, call in the WMF customer service personnel in good time.
2. After several weeks of shutdown for holidays, we recommend that the fully automatic cleaning program be run at least twice before the machine is started up again.

#### Hot water boiler data – *see rating plate*

The hot water boiler complies with the Pressure Equipment Directive 97/23/EC - Category 1, Module A.

The hot water boiler is subject to neither notification nor licensing. Each hot water boiler is subjected to hydrostatic tests before delivery to the customer.

**The operator** of such equipment is responsible for due maintenance and verification of the safety mechanism.

The machine complies with all the relevant regulations.

The operator is obliged to ensure that electrical plant and equipment is tested to establish that it is in safe working order (e.g. german law BGV A3).



This device is subject of the directive on waste electrical and electronic equipment (WEEE/EU directive) and may not be disposed of as domestic waste.



### **Preventive measures to avoid consequential machine damage**

- Any technical devices, particularly large fully automatic machines, are a potential source of danger when operated without supervision.
- We therefore recommend that the operator takes appropriate action to prevent damage, for instance installing a suitable water detector in the site water supply line.
- If the local water has a carbonate hardness of more than 5° (German hardness), a WMF water filter **must** be installed in the supply line to the machine.
- Maintenance intervals depend on how heavily the machine is used and on local water conditions, and should be fixed by agreement with your service engineer. Even in the case of light use, maintenance should be carried out at least once a year and the water filter, if fitted, should be replaced.

## 4 Machine specifications

<b>Rated power *</b>	3.3 kW	6.3 kW
<b>Rated power USA *</b>	3.9 kW	5.8 kW
<b>Hourly output **</b> Espresso Café Crème Filtered coffee ***	300 cups 200 cups 150 cups	300 cups 200 cups 150 cups
<b>Hot water output, total</b>	24 l/h (6.3 gallons/h)	48 l/h (12.6 gallons/h)
<b>Coffee bean containers</b>	1 kg (2.2 pound)	1 kg (2.2 pound)
<b>Electricity supply *</b>	1/N/PE ~ 50 Hz/230 V	3/N/PE ~ 50 Hz/400 V
<b>Electricity supply USA *</b>	1 PE ~ 240 V/60 Hz (1 ~, 3 W) 3 PE ~ 208 V/60 Hz (3 ~, 4 W)	1 PE ~ 240 V/60 Hz (1 ~, 3 W) 3 PE ~ 208 V/60 Hz (3 ~, 4 W)
<b>External dimensions</b>  Width Width (with coin checker) Height Depth	450 mm (17.7 inches) 640 mm (25.2 inches) 721 mm (28.4 inches) 550 mm (21.7 inches)	
<b>Weight (empty)</b>	Approx. 61 kg (135 pound)	Approx. 61 kg (135 pound)
<b>Continuous sound pressure level (Lpa) ****</b>	< 70 dB (A)	

Subject to technical change without notice.

\* For details of special versions, see the rating plate. The values shown here are for the basic version.

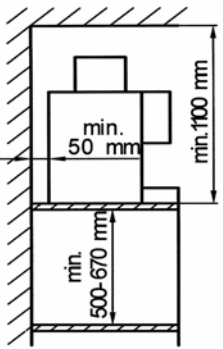
\*\* The hourly outputs shown here are APPROXIMATE VALUES. The actual output depends on such things as the amount and fineness of the ground coffee, the type of coffee, the brewing temperature, the diameter of the brewing aperture, the brewing pressure, the water hardness and the general condition of the machine (e.g. scale deposits, connection conditions, electricity supply, water quality, drain, wear, etc.).

\*\*\* ECF model version only

\*\*\*\* The A-weighted mean sound pressure level Lpa (slow) and Lpa (impulse) at the operator's workplace is below 70 dB (A) in every operating mode.

## 5 Conditions for Installation and Operation

The necessary local building work must be ordered by the user of the machine and must be carried out by authorised contractors in accordance with the general and local regulations. The WMF customer service personnel are only permitted to connect the machine to the existing outlets. They are not permitted to carry out any building work; they are also not responsible for ensuring that this work is done.

<b>Rated power</b>	<b>3.3 kW</b>	<b>6.3 kW</b>
<b>Power cable, locally provided *</b>	3 x 1,5 <sup>2</sup>	5 x 2,5 <sup>2</sup>
<b>Fuse, locally provided</b>	1 x 16 A	3 x 16 A
<b>Mains voltage tolerance</b>	230 V/400 V +6% -10% Mains dropouts <50 ms do not interrupt machine operation	
<b>Drinking water connection</b>	TW 15 (DN 15, at least DN6 or ¼") with locally provided shutoff valve and dirt filter, flow pressure at least 0,2 MPa, max. 0,6 MPa	
<b>Water quality</b>	<b>If the water has a hardness of more than 5° dKH (carbonate hardness), a WMF water filter must be installed before the machine.</b>	
<b>Water outlet line</b>	Hose DN 19, minimum gradient 2 cm/m	
<b>Ambient temperature</b>	+5 °C to +35 °C (drain the water system if there is a danger of frost)	
<b>Maximum humidity</b>	<b>80% relative humidity, no condensation, no splashwater. Do not use the machine outdoors!</b>	
<b>Installation space</b>	 <p>For trouble-free operation and safety and to permit access for servicing, there should be a free space of 50 mm between the rear and sides of the machine and the walls or any non-WMF equipment. A free height of 1100 mm should be provided above the mounting surface. The height of the mounting surface above floor level should be at least 700 mm and not more than 900 mm. If the space below the mounting surface is to be used for other equipment (such as a water filter or a grounds container), it should be between 500 and 760 high, depending on the configuration and the local connections. If the connections to the machine pass downwards through the shelf, these will require space and the available space in the lower compartment may be reduced.</p>	
<b>Installation space for water filter W x H x D</b>	Standard: 250 x 500 x 400 mm	Jumbo: 290 x 670 x 420 mm

\* The on-site electrical system must comply with IEC 364. An e.l.c.b. switch with 30 mA rated fault current to EN 61008 should be installed upstream of the unit for increased safety. An earthed socket outlet must be installed near the unit for one-phase connection. A 5-pole CEE/CEKON socket outlet to EN 60309 must be installed for three-phase connection. If the mains power cable of this unit is damaged, it must be replaced by our customer service engineer or a similarly qualified person. If the machine is permanently connected on site, a disconnecting device (master switch) to EN 60947 acting on all poles and with a contact gap of at least 3 mm must be installed upstream. The disconnecting device is also recommended for flexible connection. The mains power cable must not be allowed to come into contact with hot parts of the machine. Master switch and socket outlet are part of the on-site installation. The machine must not be installed with permanent on-site connection when mounted on a trolley.

## 6 Operation

### 6.1 Starting the machine

Before the machine is started up, the **main shut off valve** in the fresh water feed line must be opened and the **main electrical switch** outside the machine turned on.

Turn lock switch  to position “I”- (On)

The machine is then switched on and will heat up to operating temperature (approx. 12 minutes).

During the warm-up phase, the display alternately shows:

LOCKED	11:21 20.04. ^
--------	-------------------

--Warm up--
-------------

When the machine has warmed up, the display shows:

READY Pre-sel. 01	11:21 20.04.
----------------------	-----------------

“READY”:	The machine is ready for use.
“11:21”:	Current time
“20.04”:	current date
“Pre-sel. 01”	Only one brew is produced for each key press. See page 52, <b>6.2.4 Quantity selection.</b>

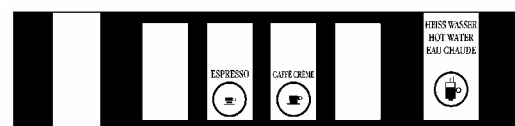
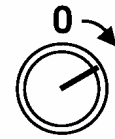
### 6.2 Making coffee

The unit has 2, 4 or 8 beverage buttons, depending on the version.

Each button can be programmed individually. WMF customer service will allocate your pushbuttons and set up the machine according to your requirements.

In the BISTRO<sup>ECF</sup> version, your unit has a second set of buttons.

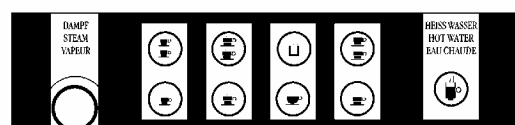
This is activated via the  button.



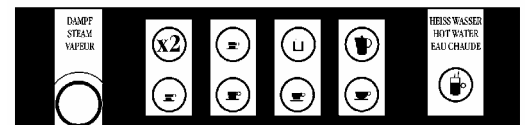
Model 8001



Model 8101 / 8201



Model 8104 / 8204



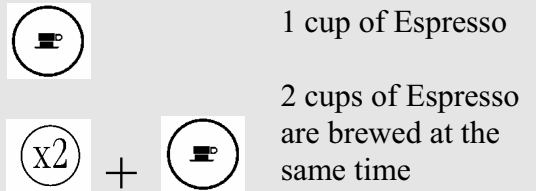
Model 8106 / 8206

**Note:**

The two-cup function is programmed via the second set of buttons:

The swivelling coffee dispenser spout **14** and combination spout **7** are variable and adapt to suit the cups you see (see Fig. 1 or Fig. 2).

Example: Espresso




**6.2.1 Espresso/Café Crème/filtered coffee\***

**Caution!** There is a danger of scalding in the vicinity of the swivelling coffee dispenser head **14**.

When the machine is ready to operate, preparation of coffee can start.  
In the BISTRO<sup>ECF</sup> version, the unit has a larger brewer for brewing filtered coffee.

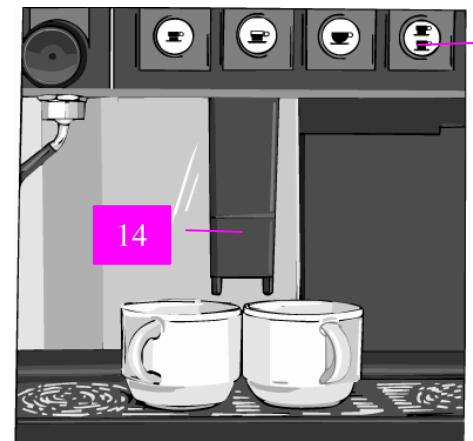
**Example: Brewing two cups of espresso.**

1. Place two espresso cups beneath the swivelling coffee dispenser head **14** (see Fig. 1).
2. Press the corresponding coffee key **5** .

During brewing, the key lights up and the display shows the following:

The used coffee grouts are collected in the integrated coffee grouts container **15**.

\* ECF model version only.



**Figure 1**



## 6.2.2 Cappuccino

**⚠ Caution!** There is danger of scalding in the vicinity of the combination spout 7.

If your WMF BISTRO is fitted with an eight key control panel, you will normally have two keys reserved for cappuccino. ☉ ☏.

In conjunction with the integrated combination spout 7, a cup of cappuccino is produced at the press of the button.

For cappuccino preparation using the steam outlet, see **6.5 Steam dispensing (not valid for USA)**

– Production of frothed milk on page 61.

1. Place one or two cups beneath the combination spout 7 (see Fig. 2). You can adjust the height of the combination spout to suit the size of the cups you use.

To do this, hold the combination spout with both hands in the area of the guide rails (see Fig. 3).

2. Press cappuccino key ☉ or ☏. The milk is drawn in from the milk pack or milk cooler provided and frothed. At the same time, the coffee is brewed and dispensed directly on to the frothed milk, and the original cappuccino is ready. Your WMF customer service personnel will set the quantity of frothed milk you desire. Milk to be frothed is drawn in from a container set up beside the machine. For reasons of hygiene, please note the following:

➔ The milk should be used up or replaced after twelve hours at the latest.

Observe the notes on cleaning under **8 Care of the machine** on page 61

## 6.2.3 Manual input

Your machine is provided with a manual input 2 for operation of additional types of coffee:

1. Open the manual input 2 to **turn off the coffee containers**

When the manual input 2 is open, the function remains active for approx. 20 seconds and the display shows:



Figure 2

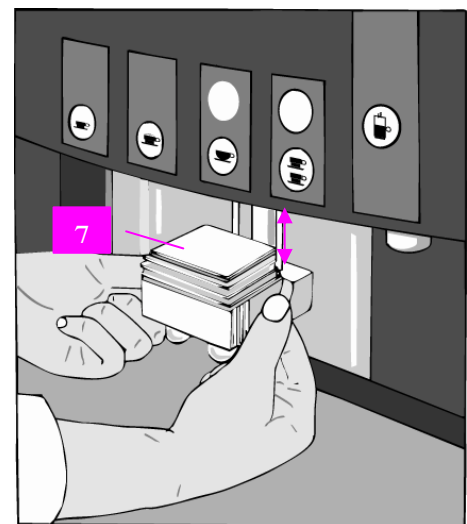
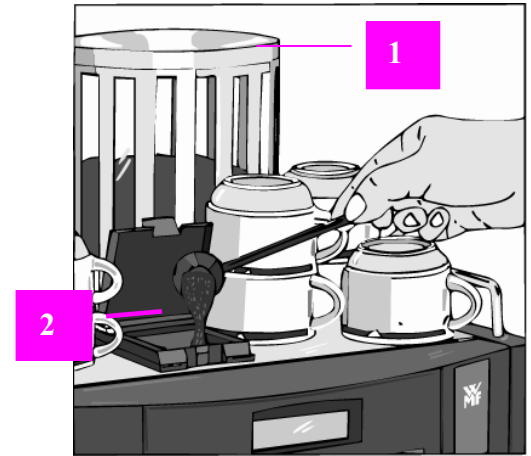


Figure 3

Insert ground coffee  
Press button!

- Drop in 1-2 measuring spoons (**max. 0,7 oz**) of **ground coffee** suitable for the brewing quantity required (see Fig. 4).



**Figure 4**

- Press the desired beverage key **5**.  
The display shows:

When the manual input **2** is closed, the machine is again ready to function.

If no brewing takes place for more than 20 seconds, the ground coffee in the grouts container is disposed of and the following message appears:

Please close  
input opening!

LOCKED	11:21
	20.04.

READY	11:21
Pre-sel. 01	20.04.

#### 6.2.4 Quantity selection

If you wish to produce several cups in sequence, you can have every key repeat automatically up to **12 times**:

Press the **+** - key to select the desired number of repeats.  
Example: 6 x

Press the desired beverage key, e.g. double café crème **5**  
(6 times **+** approx. 1.5 litres)

6 brewing cycles are now performed. When brewing is complete, the display again shows:

The pre-selected number of cycles can be increased or reduced with the **+** or **-** keys at any time.

READY	11:21
Pre-sel. 06	20.04.

2 Café Crème	11:21
Pre-sel. 06	20.04.

READY	11:21
Pre-sel. 01	20.04.

### 6.3 Coffee beans containers

The capacity of each coffee beans container **1** is approx. 2.2 pounds.

Please ensure that the coffee beans containers **1** are always topped up in good time (see Fig. 5):

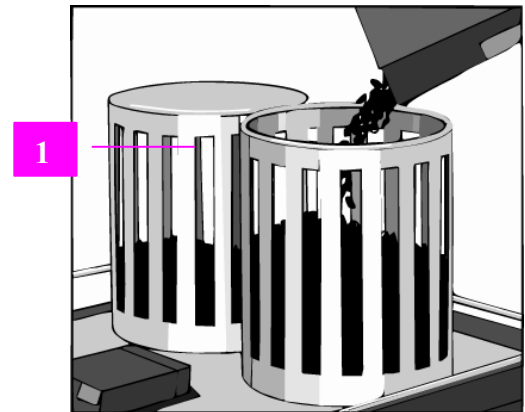


Figure 5

Special version:

A display **3** requests you to top up the coffee beans containers **1**.

Coffee dispensing is disabled when the coffee beans container **1** is empty.

Simply refill the container with coffee beans and the display will disappear.

Refill  
coffee beans left!

Refill  
coffee beans right!

### 6.4 Hot water dispensing

**!** **Caution!** There is a danger of scalding in the vicinity of the hot water outlet **13**.

Hot water in 3 variants can be dispensed through the hot water outlet **13** (see Fig. 6):

**Measure quantities:**

When the hot water key **12** is pressed, dispensing starts and stops automatically (not valid for USA).

**Start-stop function:**

Pressing the hot water key **12** starts the dispensing process and a further press stops it (not valid for USA).

**Free-flow:**

Dispensing continues for as long as the hot water key **12** is pressed.

The desired method is set by your WMF customer service personnel.

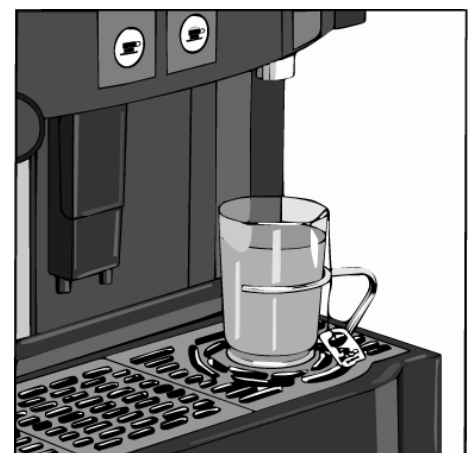


Figure 6

## 6.5 Steam dispensing (not valid for USA)

**⚠ Caution!** There is a danger of scalding in the vicinity of the steam dispensing nozzle 8.

For control, WMF BISTRO is fitted with a rotary handle for steam output 6.

### Heating drinks

1. Always immerse the steam dispensing nozzle 8 deeply in the beverage.
2. Slowly open the rotary handle for steam output.
3. When the beverage is hot, close the rotary handle for steam output 6 immediately.
4. After heating of the beverage, you should swivel the steam dispensing nozzle 8 towards the drip tray 9 and briefly open the rotary handle for steam output 6 again. Then wipe the nozzle with a moist cloth.

### Producing frothed milk

If your machine is not fitted with a combination spout 7, you can produce frothed milk with the steam dispensing nozzle 8 (see Fig. 7):

1. Use a tall, stainless steel jug with a handle (e.g. 06.3417.6040) where possible. This should be no more than half full of cold milk.
2. First immerse the steam dispensing nozzle 8 deeply in the milk and open the valve slowly.
3. Then move the jug up and down so that the outlet in the steam dispensing nozzle 8 is removed from the milk again and again.



Figure 7

**⚠ Caution! Danger of scalding.**

A large quantity of froth rapidly forms. Ensure, however, that the milk is not overheated, as this will reduce the froth quantity.

4. After milk is frothed, swinging the steam dispensing nozzle 8 towards the drip tray 9, briefly open the rotary handle for steam output 6 again. Then wipe the steam dispensing nozzle 8 with a moist cloth.

## 6.6 Coffee grouts container

The used coffee grouts are collected in the coffee grouts container **15** inside the machine. The grouts container **15** has a capacity of approx. 60 brews.

Display **3** draws attention to full grouts containers **15** with the following alternating display:

A further approx. 5 brews are possible before coffee dispensing is blocked:

Now empty the coffee grouts container **15**. The following message will appear in the display **3**:

Replace the empty coffee grouts container **15**. The display **3** will then show:

Press ENTER to confirm if you have emptied the coffee grouts container **15**, or EXIT if you were only looking. If you confirm by pressing ENTER, the coffee grouts container **15** must be emptied and removed from the machine **for at least 5 seconds**, otherwise the empty confirmation (ENTER) will not be accepted.

The display then reads:

If the message appears, the coffee grouts container **15** should be emptied and removed from the machine again for at least 5 seconds.

If the coffee grouts container **15** is removed, the display sequence starts again with:

### Warning!

The grouts container **15** must **always be emptied** before replacing.

**Replacing the grouts container **15** without emptying it will contaminate the machine and can cause damage to it.**

In a special version, the grouts can also be ejected directly into the counter. This also provides an opportunity for collection of greater quantities of grouts.

The WMF customer service personnel will then set the maximum collection quantity on the machine.

Please empty grouts container!

READY	11:21
Pre-sel. 01	20.04.

LOCKED	11:21
	20.04.

Please re-insert grouts container!

Grouts cont. empty?	
Yes/ENTER	No/EXIT

Grouts cont. not empty.  
– please empty -

Please re-insert Grouts container!

If the machine has been set to emptying mode “R” (self-service machine) by the WMF customer service technician, there will be the following differences:

If the display 3 reads:

The lock switch 4 should be turned to “R”. When the coffee grouts container 15 is removed, the following message will appear:

Replace the empty coffee grouts container 15. The display 3 will then show:

Press ENTER to confirm if you have emptied the coffee grouts container or EXIT if you were only looking. If you confirm by pressing ENTER, the following message will appear in the display:

The machine is ready to use again.

### **Warning!**

In this mode, acknowledgement that the coffee grouts container has been emptied cannot be recorded in key position “I”. It is not possible to press ENTER or EXIT.

Even if the coffee grouts container 15 has been duly removed and emptied, the display will again read:

Turn the lock switch to “R” and confirm that the coffee grouts container 15 has been duly emptied by pressing ENTER.

Then turn the lock switch to position “I”. The machine is ready for use again.

## 6.7 Display of quantities dispensed

With the key in position “A”, the quantities dispensed for every beverage key can be displayed.

1. Turn the lock switch 4 to position “A” (accounting)

The display shows the following:

2. Press the ENTER key to enter the accounting program
3. You can call up the quantities for each beverage with the beverage keys 5:

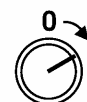
Please empty  
grouts container!

Please re-insert  
grouts container!

Grouts cont. empty?  
Yes/ENTER          No/EXIT

Please turn  
Key to „I“

Please empty  
grouts container!



Accounting...          /ENTER  
                                 [Set/->]




1 Espresso                  001895  
                                 /EXIT/->



2 Espresso	001092
	/EXIT/->




1 Café Crème	010277
	/EXIT/->

4. Pressing the  key allows you to reset the quantity displays to “0”.
5. EXIT returns you to the initial menu.

## 6.8 Personnel accounting system

In conjunction with the WMF Multicount or in conjunction with an accounting system (e.g. WMF HOGATRON), your WMF BISTRO can be fitted with a WMF personnel accounting system.



The espresso machine is then fitted with a waiter’s lock  and connected to the accounting unit.

Beverages are only released when an approved waiters key is plugged in.

Accounting for the beverages dispensed for each waiter, is accomplished by the WMF Multicount or external accounting system.

## 6.9 Sales systems

### ONE-PRICE COIN CHECKER

The WMF BISTRO can be fitted with a coin checker (Figure 8) for self-service operation. The coin checker is switched on by a switch  inside the coin box. Coins may be inserted when the “ON” lamp  is lit. The “ON” display on the coin checker is illuminated when the checker is switched on and there is a sufficient amount of ground coffee.

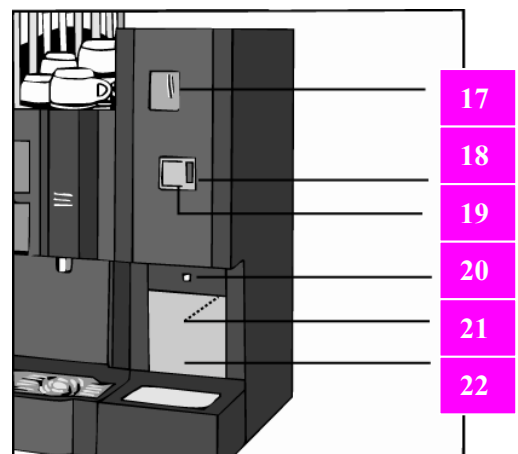


Figure 8

If the coin checker is switched off, beverages can be dispensed free of charge.

The coins or tokens inserted into the coin checker (coin slot **17**) are collected in the lockable coin box **22**.


The coin checker can be set to various selling prices. If the coin checker malfunctions, press the coin return button **18**. The cash or tokens can then be removed from the coin return chute **19**. If beverages cannot be dispensed, the coin slot is blocked and the “ON” indicator **20** is turned off.

## COIN CHANGER

See the separate instructions for operation and programming of the coin changer.

The coins or tokens inserted into the coins changer are collected in the lockable coin box.

### 6.10 Switching the machine off

 Daily cleaning should be performed before the machine is switched off.

Turn the lock switch **4** to the position “0” (Off).

When the machine has been switched off, the **main shut-off valve** in the fresh water feed line must be closed and the **main electrical switch** outside the machine turned off.


#### Machine shutdown – holidays

1. If the machine is to be shut down for an extended period of time, a general clean should be carried out first. Drain the machine to prevent frost damage, if it is to shut down for an extended period of time. In such cases, call in the WMF customer service personnel in good time.
2. After several weeks of shutdown for holidays, we recommend that the full automatic cleaning program be run at least twice before the machine is started up again.





## 7 Settings

You can alter or set the froth quality, quantity of ground coffee and brewing quantity on your WMF BISTRO.

1. Turn lock switch  to position “A” (accounting).

The display shows the following:

2. The  key calls up the setting program.
3. The  key provides you with information on the next servicing date and the condition of the water filter, if installed.



Further information can be found in Chapter 9 **Error messages and displays** on page 67, as well as under 9.2 **Error messages for the operator** on page 67.



### 7.1 Setting froth quality

Press the ENTER key to enter the setting program:


Pressing the  /  keys allows you to choose between the Froth Quality and Portioning Quantities setting programs.

Press the ENTER key to enter the froth setting program.  
The display shows the following:

The froth quality can be set individually between 1 – 16 by pressing the  /  keys.

-  Froth gets finer → less froth volume
-  Froth gets coarser → more froth volume

Press and hold down the ENTER key for 3 seconds to start froth dispensing. The setting value can be changed while froth dispensing is taking place. This process stops automatically after 20 seconds or can be stopped by pressing the EXIT key.

When the required result is reached, turn the key switch  to position “I” to store the new value.



Accounting...	/ENTER [Set/->]
---------------	--------------------

Set/Select... [Info/->]	ENTER [Acc./->]
----------------------------	--------------------

Select Froth Quality / < / > /	ENTER/EXIT
-----------------------------------	------------

Froth Quality fine/-	009	1...16 coarse/+
-------------------------	-----	--------------------

## 7.2 Quantity selection

Pressing the < / > keys allows you to choose between the Froth Quality and Portioning Quantities setting programs.

Press the desired beverage key **5** for which the setting is to be changed (e.g. “1 cup espresso”):

The display will then flash to show you which values you can change in this setting. This is done by pressing the + - buttons. Once you have reached the desired value, press the > - button to move on to the next value to be set.

For example, if you press the cappuccino button, the display will read:

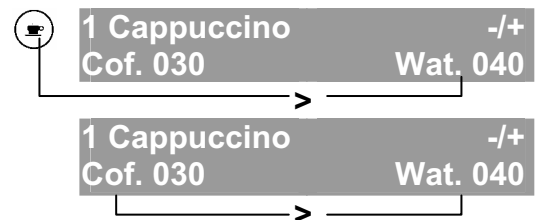
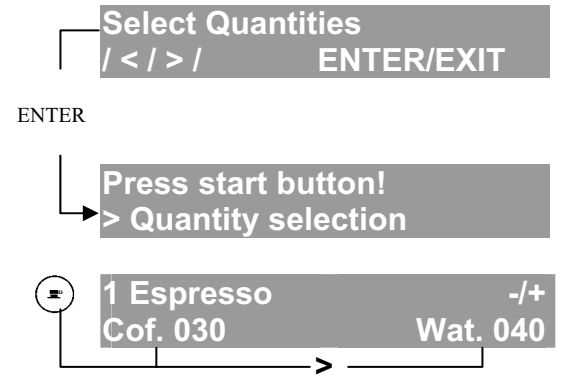
The coffee value will flash. After changing it, press the > - button to change the water value.

Press the > - button again, and the display will read:

If this is set to the value you require, please proceed in the same way for all the other beverage buttons.

For example hot water:

When you have made all the changes for all the beverages you require, turn lock switch to position “I”, and all the new values are stored.



## 8 Care of the machine

### 8.1 Daily cleaning

Daily cleaning of the WMF BISTRO is extremely important to ensure correct operation of the machine and top coffee quality. 26 hours after switching on the machine, the display **3** will remind you that it is time for the daily cleaning program.

**To make sure the cleaning program is run, the machine will switch off automatically after another 24 hours if the cleaning program has not been run.**

The cleaning program then has to be run before the machine can be started up again.

**If the machine is switched off without being cleaned after operation, and if more than 26 hours have passed since it was last cleaned when it is switched on again, the machine will remain out of operation after heating up.**

The cleaning program must then be run through before the machine can be started up again.



#### **Caution!**

There is a risk of scalding and burning in the area of the combination spout **7**. Take care not to press any of the coffee keys **5** if the combination spout **7** has been removed.



#### **Caution! Health hazard!**

When handling the cleaner, **always follow the safety instructions on the pack.** The cleaner is caustic and can hurt. Cleaning fluid flows out of the swivelling coffee dispenser head **14** and combination spout **7** during cleaning.

If your WMF BISTRO includes a combination spout for frothing milk, the following cleaning operations must be run through:

**8.1.1 Cleaning the machine** on page **62** and **8.1.2**


**Cleaning the combination spout** on page **63**.

Only the cleaning operations described in

**8.1.1 Cleaning the machine** on page **62** need be run through if your WMF BISTRO has a pivoted coffee spout.

### 8.1.1 Cleaning the machine

Please use only special cleaning tablets (Order no. 33 0681 1000) to clean your WMF BISTRO.

Turn the lock switch  to position “R” (cleaning).

The following display appears if your WMF BISTRO is fitted with a combination spout:

The following display appears if your WMF BISTRO is fitted with a pivoted coffee spout:

In both cases, press ENTER to start the automatic cleaning program. The display then shows the individual steps:



CLEAN>Machine / ENTER  
Milk frother / +

Cleaning cycle?  
Start program / ENTER

ENTER Please empty grouts  
Container! / ENTER

ENTER Please re-insert  
Grouts container!

Position container  
under spout / ENTER

ENTER (This display only appears when the machine is  
**not** connected to a drainage pipe)

Insert  
Cleaner! / ENTER

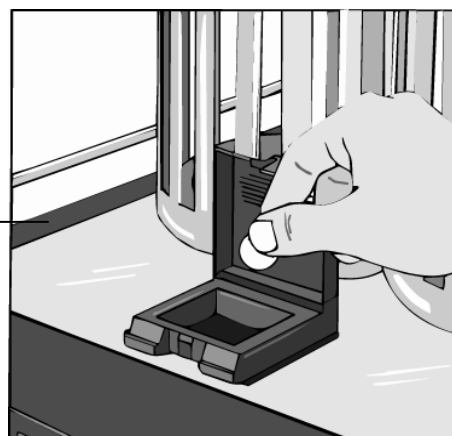


Figure 9

ENTER Please close  
Input opening

➔ The cleaning program runs.

While the cleaning program is running (duration approx. 5 minutes), the display shows the following:

CAUTION! CLEAN CYCLE  
-- NO ACCESS--

If the machine is excessively soiled, this will be detected by your WMF BISTRO and the following cleaning prompt will appear on the display:

-> Machine OFF / ON  
Start CLEANING new!


The automatic cleaning program must then be run again (see **8.1.1 Cleaning the machine** on page 62)

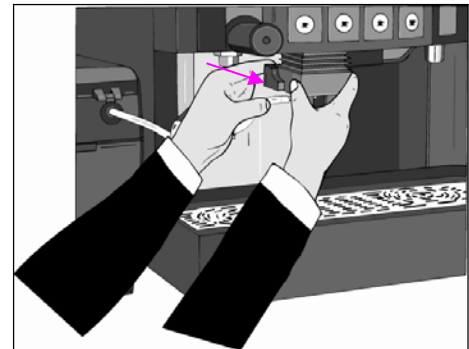
### 8.1.2 Cleaning the combination spout

#### **Warning!**

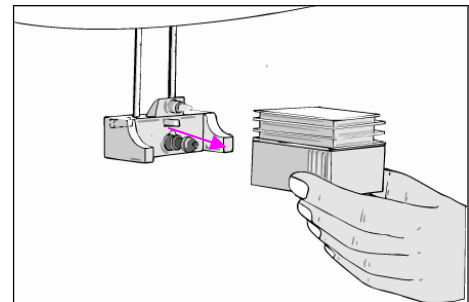
For reasons of hygiene, all surfaces in contact with milk should be cleaned at least once a day. The milk intake hose should therefore be replaced at regular intervals.

Proceed as follows:

1. Press the release lever at the back of the combination spout  and pull spout forward to remove (see Fig. 10 and Fig. 11).

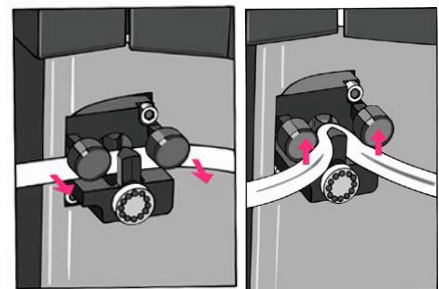


**Figure 10**



**Figure 11**

2. Remove the milk intake hose from the clamping valve by pulling both ends of the milk intake hose forward and lifting it up out of the bracket (see Fig. 12).

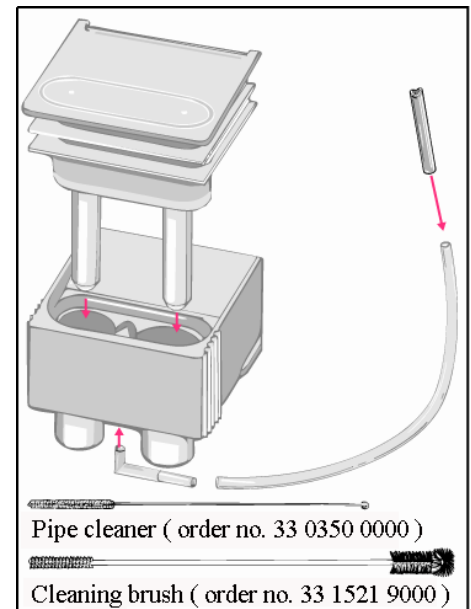


**Figure 12**

#### **Warning!**

Risk of injury when removing and fitting the milk intake hose in the clamping valve

3. Clean the connector to which the combination spout 7 was fitted with a damp cloth.
4. Dismantle the combination spout 7 and clean it thoroughly (completely) under running warm water. Clean the ducts with the pipe cleaner and cleaning brush supplied.



**Figure 13**

5. Then place all loose parts (including pipe cleaner, cleaning brush, milk intake hose, intake nozzle and angle piece) in cleaning solution for at least 5 hours. To prepare this cleaning solution, fill a container with 0.5 l of lukewarm water, add 5 ml of WMF special cleaner (Order No. 33 0683 6000) from the dosing bottle and stir thoroughly. The parts must be completely covered by the cleaning solution. (After this, the parts are sterile. It is important to ensure no new germs come into contact with them during subsequent handling).
6. Rinse parts thoroughly under running (preferably warm) water.
7. Reassemble the combination spout 7 and fit to machine.
8. Now draw off one portion of hot water and turn the lock switch to “R”.
9. Place the milk intake hose in the hot water and keep it there. Then press the ⊕ button. The steam flow completes the cleaning process.

**⚠ Caution!**

**Risk of scalding** – cleaning fluid flows out of the combination spout 7.

Cleaning fluid will be flushed through the combination spout 7 for about 1 minute.

Then turn the lock switch to “T”.

**Further recommendations:**

- If there is no time to carry out point 5 due to operating reasons, we recommend purchasing a second froth head assembly
- It is advisable in any case and especially in case of low throughput or when using non-cooled milk to carry out intermediate cleaning after four to six hour's operation. The procedure is as follows:

Turn lock switch to “**R**“. Prepare cleaning solution as described in point 5 (5 ml of WMF special cleaner Order No. 33 0683 6000 from the dosing bottle in 0.5 l of lukewarm water). Place milk intake hose in solution and press ⊕ button. Cleaning solution will be flushed through the combination spout for about a minute. Repeat twice with fresh water, then turn the lock switch back to “**I**“.

- Never use leftover milk from the day before to make froth.

### **Foamer rinsing (optional):**



#### **Note:**

Foamer rinsing is **no substitute** for daily cleaning. You should still clean the coffee machine and the milk foamer every day.

Foamer rinsing involves rinsing the milk foamer with cold water, hot water and steam at an adjustable time interval after dispensing a milk beverage. This is done to remove milk residues. When 20 minutes (the time can be adjusted by WMF Customer Service) have elapsed since the last milk beverage was dispensed, foamer rinsing starts automatically:

1. Your WMF coffee machine display flashes:  
**Caution! Foamer rinsing**
2. The milk foamer is rinsed with cold water, hot water and steam.

The complete rinsing process takes about 15 seconds. Coffee dispensing is disabled during this time. If the set time happens to elapse while you are preparing coffee, foamer rinsing will start 15 seconds after the last beverage is dispensed.

**Note:**

Ensure that no jugs or other containers are beneath the coffee spout while foamer rinsing is taking place. Do not reach under the combination spout.

## 8.2 General cleaning

When the machine has cooled down, clean the panels and drip plate with a moist cloth and then rub them dry with a fine wool or chamois cloth. Avoid abrasive cleaning powders as these can cause scratches.

We recommend the following product for care of the metal panelling parts:

Matt surfaces: WMF Puragan® forte

### Order numbers for WMF's machine care program:

Special cleaner for milk dispensers  
Order no. **33 0683 6000**

Puragan forte  
Order no. **14 2831 9990**

Pipe cleaner  
Order no. **33 0350 0000**


Special boiler cleaner  
Order no. **33 0680 8000**

Special cleaning tabs  
Order no. **33 0681 1000**

Cleaning brush  
Order No. **33 1521 9000**

## 9 Error messages and displays

### 9.1 Error messages

 The error messages listed below can and must only be cancelled by **WMF or authorised customer service personnel!**

A diagnostic system is installed on your WMF BISTRO. Any faults are indicated on the display **3**. However, the fault messages listed below may also be caused by faults in the mains power supply. A fault message consequently appears on the display when faults F1 to F5 appear for the first time in normal operation.

The following message may appear on the display, for example:

Fault! [F1]  
-> Machine OFF / ON


Switch the machine off and on again.

If the fault recurs, the following message appears on the display:

Fault! [F1]  
Call customer service

Please contact your local WMF or authorised customer service centre so that the fault can be remedied as quickly as possible. Remember to specify the fault number (e.g. F1) so that the fault can be identified.

### 9.2 Error messages for the operator

 The error messages described below can be cancelled by the operator.

No water pressure

Open the water supply line

Refill  
Coffee beans left!

The message disappears automatically when the container is filled \*

Refill  
Coffee beans right!

The message disappears automatically when the container is filled \*

Please close  
Input opening!

Manual input **2** is open – please close

Please empty grouts  
Container /ENTER

Please empty grouts container (see **6.6 Coffee grouts container** on page **55**)

\* This message only appears on machines with built-in light barriers.

Please re-insert  
Grouts container!




The message disappears automatically when the container is re-inserted

Please proceed  
cleaning cycle



The message disappears automatically when cleaning is carried out

### 9.3 Information for the operator

 Please bear in mind that this is a professional commercial coffee machine. A machine of this type requires regular maintenance by our WMF Customer Service. The maintenance interval depends on how heavily the machine is used, but maintenance should be carried out at least once a year.  
The displays listed below inform the operator of certain operating conditions.

READY 11:21  
Pre-sel. 01 20.04.^



Machine is operational and the heating is on “^”.

LOCKED 11:21  
20.04.^



The display always alternates with a “Message for the operator”.

Maintenance!  
Call customer service






This display alternates with the prompt “Heating!” after switching on if the service interval or set number of brews has been exceeded.

Filter Exchange!  
Call customer service



This display alternates with the prompt “Heating!” after switching on when the set number of litres for the WMF water filter has been reached.

You can now obtain further information on the next servicing date, the number of brews of your WMF BISTRO and the condition of your WMF water filter.

For this purpose, turn the lock switch  to “A” (Accounting) and press first the  key and then the  key. The following display appears for four seconds:

Info Mainten. 12.1998.  
006347/030000 brew.




Next service due in December 1998. The brewing unit must be serviced after 30.000 brews, 6347 brews have already been completed.

If a water filter is installed and the filter change display has been activated by the WMF customer service technician, the following display will appear for four seconds:

Info Filter Exchange  
01512 / 02500 Litres



The WMF water filter must be replaced when 2500 litres of water have passed through. 1512 litres have already been used.

 **Note:** Scale deposits will form in the machine and cause hygiene problems if the filter is not changed in good time.

## 10 WMF Customer service

WMF's comprehensive service allows every area to be reached in a short period of time. Our personnel are experienced experts and carry special tools and the original spare parts required at all times so that malfunctions can be eliminated on the spot.

In order to ensure regular machine inspection, we recommend that a regular machine maintenance schedule be arranged with your local WMF or authorised service technician.

## **11 Liability**

WMF will be liable as follows for justified defects of quality:

All products or services that exhibit a defect of quality within the statutory period of limitation shall at the option of WMF be repaired or replaced free of charge if the cause of the defect of quality occurred before the passing of risk.

Claims for defects of quality become statute-barred in twelve months. The period commences at passing of risk. The above periods do not apply if longer times are prescribed by law.

The liability period is extended to 24 months from passing of risk if at the time of concluding the contract of sale the customer concludes a maintenance agreement for regular maintenance of the coffee machine purchased. The extension of liability period only applies if the maintenance agreement concluded has a minimum term of two years.

If commissioning of the machine is delayed by more than four weeks for reasons for which WMF is not responsible, the warranty period commences four weeks after delivery of the machine to the customer.

The customer must notify WMF promptly in writing of any defects of quality. Replaced parts become the property of WMF.

In all cases, WMF shall first be given an opportunity of subsequent performance within an appropriate time. The customer shall place the subject of the complaint at WMF's disposal.



**No warranty** applies in respect of:

- All parts subject to natural wear and tear. These include seals, ink ribbons and portioners;
- Defects due to the effects of weather, scaling, chemical, physical, electrochemical or electrical influences not attributable to any fault of WMF;
- Failure to use a water filter even though local water conditions require the use of a water filter and defects are thereby caused. The customer is always notified in the order acknowledgement if use of a water filter is necessary;
- Defects due to failure to follow the instructions for the use, maintenance and care of the machine (e.g. WMF operating and maintenance instructions as specified in the instructions for use/operator's manual for the particular coffee machine model);
- Defects due to improper or incorrect use, failure to use WMF original parts or defective installation by the customer or third parties or defective or negligent treatment, or the consequences of modifications or repairs carried out improperly and without our consent by the customer or third parties.

Claims for damages on the part of the customer, on any legal ground, in particular based on non-observance of duties arising from the relationship under the law of obligations and tortious act are excluded.

## 12 HACCP Cleaning Concept

Dear Customer

The purpose of this information for our customers is to help you to comply with the statutory regulations on food hygiene when processing milk beverages from WMF coffee machines.

The statutory "Ordinance on Food Hygiene dated 5 August 1997 stipulates that you must ensure that your guests do not suffer any health hazards as a result of consuming foods which you have dispensed.

The **HACCP (Hazard Analysis Critical Control Points) concept** demanded by these regulations requires that you analyse the risk in your establishment in order to identify and remedy any hazard points in conjunction with food hygiene. Monitoring procedures, as well as possibly also test and inspection procedures, must be defined and enforced in this context.

When correctly installed, serviced, maintained and cleaned, the WMF coffee machines meet all the requirements of the aforementioned regulations. The milk beverages dispensed from WMF coffee machines also constitute a **hazard point** under food hygiene regulations if **the machine is not cleaned and serviced correctly**.

### **The following points must therefore be noted when drawing up your HACCP concept:**

#### **Sterilize your milk system every day!**

Strictly follow the Operating Instructions when cleaning the milk dispensing system. This will ensure that your system has been sterilized before commencing operation.

#### **Always start with a fresh pack of refrigerated long-life milk!**

Long-life milk in unopened packages normally does not contain any harmful pathogens. For this reason, you should never start work with an open pack. When opening a fresh pack, always ensure that everything remains absolutely clean! Dirty hands, scissors or knives can contaminate the milk with germs when the pack is opened.

#### **Keep the milk refrigerated!**

The milk should be refrigerated before use (temperature: approx. 6 – 8 °C). The higher the temperature of the milk, the more rapidly germs will multiply.

- Refrigeration is only unnecessary if the pre-chilled, fresh milk is used up within not more than 3 hours (corresponds to roughly 15 cups of Cappuccino for 1 litre of milk). The milk only warms up marginally during this time.
- If less milk is consumed, it should also be refrigerated during operation. Various possibilities are available from WMF AG for this purpose. Here too, however, it is important to ensure that the milk is chilled beforehand. It takes longer to cool warm milk and this should therefore be done before opening the pack of milk. Always keep an additional unopened "extra" pack of milk in the WMF chiller or on hand in your coldstore / refrigerator.
- If you cannot refrigerate the milk during operation and require only small quantities of milk, you should additionally clean the system at the latest when changing to a fresh pack of milk (see Operating Instructions)!

# HACCP Cleaning Concept

**Always use refrigerated milk in order to exclude all risks of health damage due to microbacteria!**

**Cleaning procedure:**

1. Run through the all-automatic cleaning program for the coffee machine and disposal of the coffee grouts
2. Clean the milk frother (immerse in cleaning fluid for 5 hours!)
3. Clean or replace the milk frother after 4 hours of operation (this is absolutely essential if the frother is only used occasionally and when using unrefrigerated milk)
4. Clean the machine in general, i. e. the enclosure, drip tray

Month  Year

Date	Cleaning procedure			General cleaning	Signature	Date	Cleaning procedure			General Cleaning	Signature
	1	2	3				1	2	3		
			<b>Time</b>	4					<b>Time</b>	4	
<b>1.</b>						<b>17.</b>					
<b>2.</b>						<b>18.</b>					
<b>3.</b>						<b>19.</b>					
<b>4.</b>						<b>20.</b>					
<b>5.</b>						<b>21.</b>					
<b>6.</b>						<b>22.</b>					
<b>7.</b>						<b>23.</b>					
<b>8.</b>						<b>24.</b>					
<b>9.</b>						<b>25.</b>					
<b>10.</b>						<b>26.</b>					
<b>11.</b>						<b>27.</b>					
<b>12.</b>						<b>28.</b>					
<b>13.</b>						<b>29.</b>					
<b>14.</b>						<b>30.</b>					
<b>15.</b>						<b>31.</b>					
<b>16.</b>											

